

OPAQUE OR ANALYTICAL ULTRACENTRIFUGES¹

JAMES W. McBAIN

Department of Chemistry, Stanford University, California

Received January 30, 1939

When sand or gravel is dropped into quiet water, it falls at a definite rate which reflects its size or weight of particle. If there are several sizes, each has its corresponding rate. The same is true for colloidal particles and ordinary molecules, if the water is placed in a sufficiently intense field of force and yet held quietly free from vibration and stirring. This is the principle of the ultracentrifuge.

DEFINITIONS AND PURPOSES

Ultracentrifuges are centrifuges of low or high power containing a fluid in which convection is avoided, so that molecules or particles may sediment and diffuse undisturbed. In transparent ultracentrifuges these processes may be followed by measuring the absorption of light or the index of refraction.

In analytical ultracentrifuges all the expensive optical accessories required for all forms of transparent ultracentrifuges are dispensed with. Instead, at any given time, a whole or a portion of the contents of the ultracentrifuge is removed for analysis by any suitable chemical, physical, or biological method. This analysis determines what movement of each component of the fluid has occurred through a definite cross section of definite radius in a definite field of force.

Velocity of sedimentation, s , is customarily expressed as the linear radial rate of movement in centimeters per second per dyne of centrifugal force. It is an arbitrary convention to record as s_{20} the observed value of s multiplied by the ratio between the measured viscosity of the actual system and that of water at 20°C., correcting the density of the solution to the value for pure water at 20°C.

The sedimentation velocity of ordinary molecules requires such high centrifugal fields that it is at present beyond the range of any existing

¹ Presented at the Symposium on the Physical Chemistry of the Proteins, held at Milwaukee, Wisconsin, September, 1938, under the auspices of the Division of Physical and Inorganic Chemistry and the Division of Colloid Chemistry of the American Chemical Society.

transparent ultracentrifuge. As will be seen, however, it should lie within the scope of the high-power analytical ultracentrifuge.² Sedimentation velocity is measured in the highest practical field with the dual purpose of rendering it so rapid as to be undistorted by diffusion and of discriminating more sharply between different particles present. Direct analytical measurement of each moving component may serve to determine the composition of a particle and also to show which components move or vary independently. The dependence of the rate upon various factors yields such information as that of association or of the splitting or dissociation of proteins in solvents of exceptionally high dielectric constant (3, 4, 32, 34, 39, 40) or with certain added agents. With certain restrictions it may measure the density and hydration of the particles or molecules (18, 15, 7).

Sedimentation equilibrium is measured in comparatively low fields, except for the smallest molecules. It is the final stationary state where, at any point, velocity of sedimentation is exactly balanced by diffusion. Its advantage is its thermodynamic relation to molecular or particle weight independent of shape although subject to the usual restrictions as to activity coefficient. In practice this has been set equal to unity. The effect of extreme length and flexibility of a molecule, which distorts ordinary molecular weight determinations (26), has not yet been sufficiently examined in the ultracentrifuge. In mixtures and polydisperse systems each component attains its own dynamic equilibrium. In the opaque ultracentrifuge one analysis at one speed is enough to measure the equilibrium, provided the analysis singles out a monodisperse constituent. Otherwise, runs at different speeds and preferably with analysis of more than one portion of the sedimented column are required.

THEORY

In the analytical ultracentrifuge the one factor, sedimentation velocity, may be isolated for exact measurement, uninfluenced by the other factor, diffusion. In contrast to the transparent ultracentrifuge it is a matter of complete indifference as to whether or not there is a moving boundary somewhere in the immobilized portion. The precision of the result depends upon the quantitative analysis, the measurement of the radius, temperature, and speed, together with the precautions taken in design

² *Footnote added in proof:* Mr. F. A. Leyda in the author's laboratory has measured the sedimentation velocity of sucrose, using Pliofilm 0.0015 in. thick for spacing discs in the insert and using only 2110 r.p.s. with the 37-mm. rotor. He obtained $s_{20} \times 10^{13} = 0.170$ and 0.174. When these observations were corrected for diffusion, they became 0.21, whereas the calculated theoretical result for anhydrous sucrose is 0.23. The lower value is reasonably ascribable to hydration.

and manipulation to eliminate the disturbing effects of convection and diffusion. The analytical method is therefore potentially the most accurate and is still applicable where, owing to the absence of a boundary, the transparent ultracentrifuge fails.

Mason and Weaver (17, 38) have supplied the theory of the phenomena for a homogeneous field or where the effects of radially may be neglected, but recently Archibald (1) has supplied the complete solution for a truly radial or centrifugal field. In both cases it is assumed that diffusion follows Fick's law, completely uninfluenced by the centrifugal field. The movement at any given height in the cell is equal to that due to sedimentation velocity less the diffusion occasioned by the resultant concentration gradients. Hence, initially, diffusion occurs only at the extreme top and bottom of the cell, and sedimentation through any intermediate position is unaffected. This and the following statements are based upon their equations (17, 38, 1) and also the illustrative diagrams for numerical examples.

An appreciable fraction of the material, usually ample for analysis, moves into the lower portion of the cell before the effects of the resulting diffusion gradients reach a level just under the middle of the cell. This is true even where no boundary can form in the upper part of the cell and where by the optical methods only sedimentation equilibrium could be measured. It is likewise true of all cases where a boundary is formed, and hence the sedimentation velocity may be measured from the very beginning, since in *direct* air-driven centrifuges only a fraction of a minute is required to attain full speed. In contrast, with the optical method, the uppermost portion of the cell cannot be used, since time is required for the boundary to be set up, and, as Mason and Weaver have shown, the initial period is occupied in a mere reduction in concentration at the top of the cell before a boundary develops. In both analytical and transparent ultracentrifuges the bottom portion of the cell is not available for measurement of sedimentation velocity, unless it so happens that diffusion is eliminated through the permanent adherence of all sedimenting particles to the periphery of the cell. Summing up, the considerations which limit the applicability of the transparent ultracentrifuge apply in much less degree to the analytical ultracentrifuges, and, if the method of analysis is sufficiently accurate, the latter should be unrestricted in their applicability.

There is one additional diffusional effect to be considered in such opaque ultracentrifuges as those of McBain and Leyda (21), where convection may occur below an immobilized portion of the cell. Diffusion into the immobilized portion must occur. However, it is readily shown by calculation that, since the sedimented material is immediately distributed

throughout a volume of liquid approximately equal to the immobilized portion, this initial diffusion begins at zero rate and only gradually develops into an amount sufficient to affect the measurement of sedimentation velocity. If desired, it can always be taken into account by the usual Fourier calculation.

METHODS OF IMMOBILIZATION

The simplest equipment is the one-piece hollow rotor of Henriot and Huguenard (14), which is directly air-driven. This rotor is photographed in figure 1, and shown in cross section in figure 2. It is unsurpassed for centrifugal force and costs only a few dollars to make. Although admitting

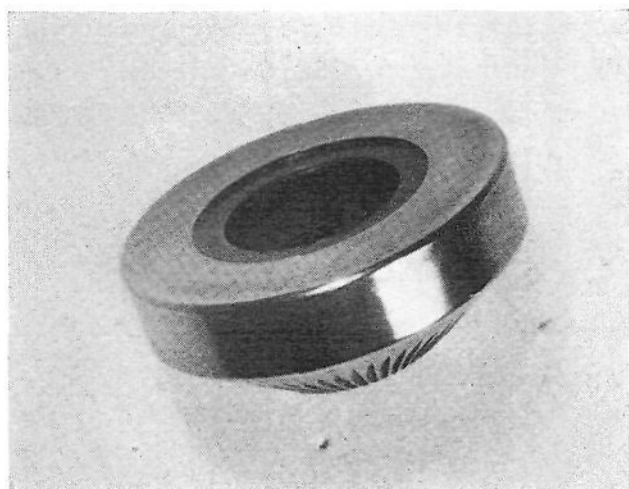

FIG. 1

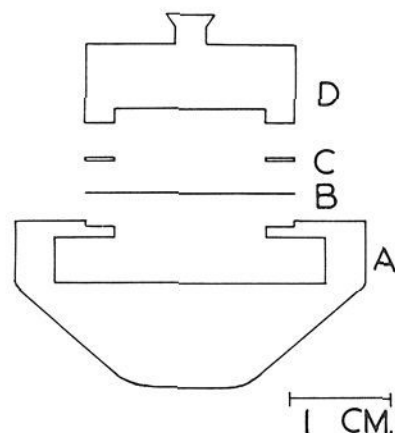

FIG. 2

FIG. 1. One-piece spinning top with depression for window of Cellophane, or of metal, etc.

FIG. 2. One-piece hollow steel rotor (A) with cover (B), ring (C), and brass weight (D) to melt on adhesive.

of quantitative results (see later), in this form it is not an ultracentrifuge, but only a convecting centrifuge.

The method of immobilization by a jelly was introduced by McBain and Stuewer (23) and was first applied to measurement of the rate of sedimentation of the jelly structure itself. With 0.3 per cent agar jelly, it gave the same sedimentation rate (65×10^{-13}) as was given (63×10^{-13}) by the transparent ultracentrifuge of McBain and O'Sullivan (22). The swelling pressures of the jelly were also measured. The addition of soap curd was successfully used by McBain and Tostado (20) in measuring the sedimentation equilibrium of sucrose. However, such additions obstruct the rate of sedimentation, as was observed with hemoglobin.

The most general method of immobilization is to place the whole or a

part of the liquid between parallel horizontal disks or washers spaced close enough to immobilize by friction the liquid between the horizontal plates. This method possesses the further advantage that the disks or washers allow ideal unobstructed radial sedimentation over 360°. They must be chosen of material which is strong enough to withstand the centrifugal field and has no action upon the material studied. They have been used for both aqueous and non-aqueous systems.

One might fear a "wall effect" or an influence of the contiguous baffle surfaces. However, according to H. A. Lorenz (16), the force of friction, when a particle with radius r is falling parallel to the wall at a distance l , is increased over that for free fall in an infinite body of liquid taken as unity by the factor

$$1 + \frac{9}{16} \cdot \frac{r}{l}$$

Again, according to Faxen (10), the frictional force for a particle falling in the middle between two parallel walls is increased in the ratio

$$\frac{1}{1 - 1.004 \frac{r}{l} + 0.418 \frac{r^3}{l^3} - 0.169 \frac{r^5}{l^5}}$$

Hence, if for egg albumin $r = 22 \text{ \AA}$. and $l = 0.1 \text{ mm.}$, the correction is negligible, affecting only such particles as are within a distance of a few diameters from the wall. This is borne out by the measurements of McBain and Leyda (21) on isoelectric egg albumin, for which they found the value $s_{20} = 3.56 \times 10^{-13}$, in agreement with Svedberg's value of 3.55×10^{-13} .

While it is always possible to make use of the simple one-piece rotor, it is generally more convenient to place suitable inserts in a two-piece rotor. With the one-piece rotor segments cut radially from washers are piled around the inside of the rotor like brick-work, but with small overlap so that the segments immobilize almost their own volume of liquid between successive horizontal surfaces (19). First, however, a horizontal circular distributing disk is placed in the bottom of the rotor (folding and then flattening it). This permits measurement of rate of sedimentation while the rotor is running by dropping in a heavier liquid, such as carbon tetrachloride, through the distributing disk to force uniformly inwards its own volume of immobilized liquid, which is then removed by a scraping pipet for analysis.

The only convenient and uniformly successful two-piece rotor is that described by McBain and Leyda (21) and shown in figures 3 and 4. These

direct air-driven rotors are distinguished from those of Svedberg and of Beams and Pickels and collaborators by the fact that they maintain themselves at the temperature of the slip-stream of air. The driving air, as in the McBain and O'Sullivan transparent ultracentrifuge, is first passed

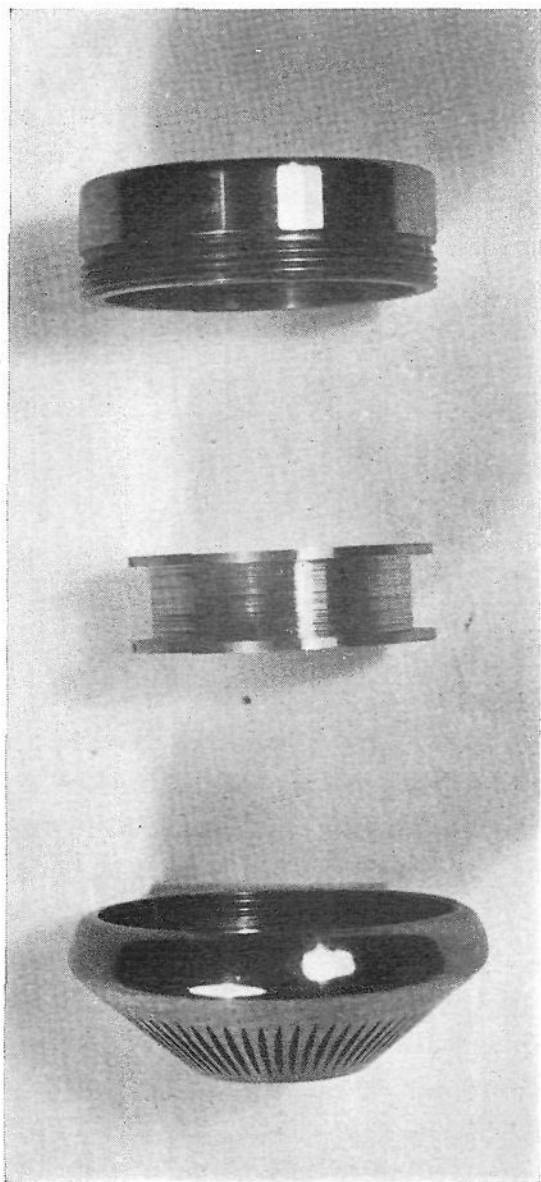

FIG. 3

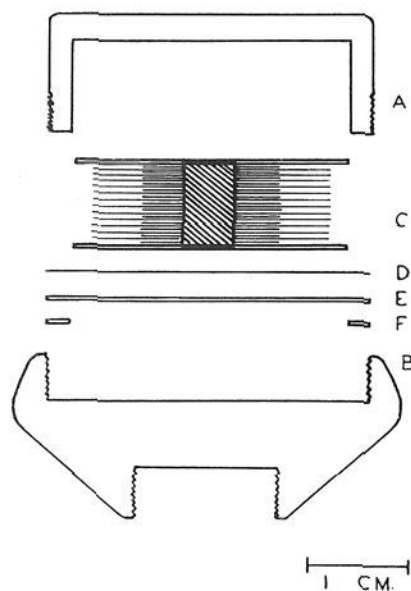

FIG. 4

FIG. 3. Two-piece McBain and Leyda steel rotor with immobilizing insert

FIG. 4. Two-piece McBain and Leyda rotor. A, steel cover; B, rotor cone; C, immobilizing disk; D, Pliofilm disk; E, metal disk; F, slip ring.

through a copper coil immersed in a thermostat, so that the rotor and its contents are maintained at any desired temperature with the same constancy as the thermostat.

The principle of the McBain-Leyda rotor (figures 3 and 4) is that a

thrust joint is formed, remaining water- and oil-tight in spite of the centrifugal force subsequently applied. The shell, A, holds the immobilizing insert, C, and the liquid. It screws into the rotor cone, B, its edges forming a seal against a disk of Pliofilm, Cellophane, or other suitable plastic, D, which rests against a rigid loose disk, E, under which is placed a loose metal slip ring, F. The ledge of the rotor cone, with female screw, is made shorter and thicker than the annular walls of the shell, A, the elastic expansion of which into the grooves of the screw assists in maintaining the tight joint during centrifuging. The rotor is assembled upside down and weighed. The liquid is sufficiently immobilized by inserts so that the rotor

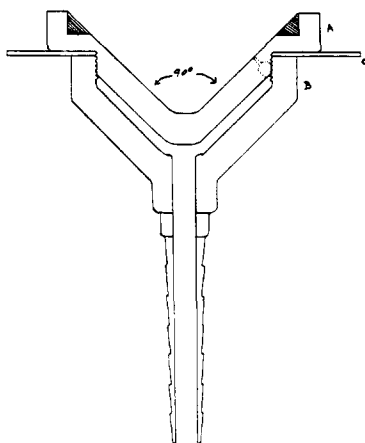

FIG. 5

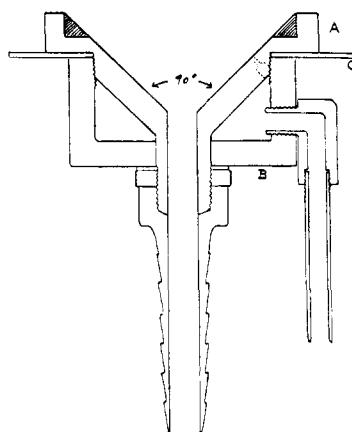

FIG. 6

FIG. 5. Cross section through simple stator. A, aluminum cone with brass ring inset and holes for driving air; B, wind-box or manifold; C, aluminum disk to be held by rubber and sponge rubber.

FIG. 6. Cross section through stator with central air-inlet to relieve vacuum under rotor to any desired extent.

may be carefully stopped with the fingers and reweighed prior to dismantling for analysis, to make sure that the weight has remained constant to 0.0001 g. With the insert used by Leyda, the total volume of liquid was 2.2 cc., of which the inner half was immobilized.

The typical stators are shown in figures 5 and 6. Figure 6 adopts a suggestion of Beams, namely, that a regulated amount of air be allowed partially to relieve the vacuum under the middle of the rotor. With some rotors this is unimportant, whereas others run more smoothly and up to 10 per cent faster. No motion of the rotor should be visible under the microscope, that is, to 0.001 mm. The stator in figure 5 consists of a

distributing air chamber into which is screwed a cone of 90° angle through whose sides are bored six to twelve holes with a No. 71 drill held at an angle of 65° to the vertical and an angle of 35° to the horizontal. A brass or bronze ring is shown inserted to give longer wear during chance contact, although the rotor is normally carried by the air. The tube leading to

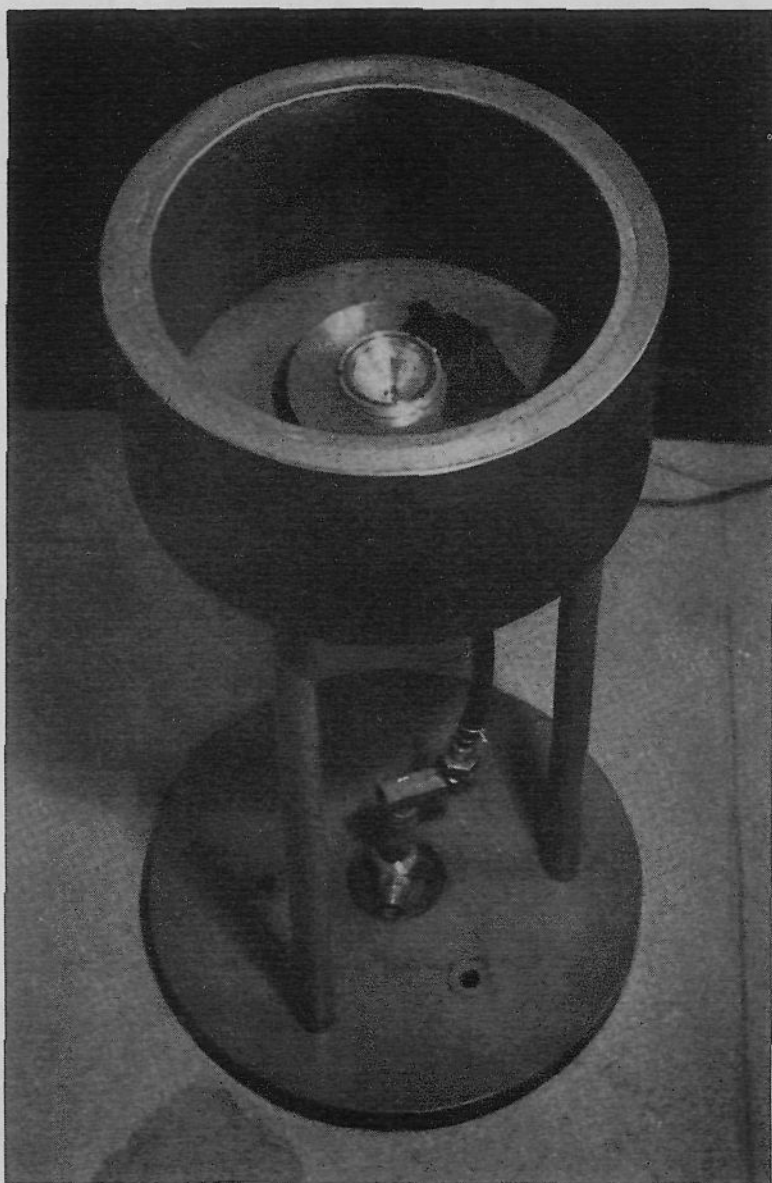

FIG. 7. Stator mounted in lead-lined steel guard (complete)

the stator may be suitably weighted with attached clamps for smoother running. Its upper part should be steadied by pieces of sponge rubber.

A complete assembly is shown in figure 7, with a safety guard for occasions when the rotor flies apart. The original rotor of McBain and O'Sullivan has been in fairly continuous use, running at several thousand R.P.S., during three and a half years without accident.

IMMOBILIZING INSERTS

Various inserts embodying the same principle have been designed for different purposes and have been described elsewhere (19, 21). Here it is sufficient to mention the insert of McBain and Leyda, shown in figures 3 and 4, consisting of a pile of about one hundred circular disks about 0.08 mm. thick and alternately of large and small diameter. The smaller disks thus serve as vertical spacing pieces between the horizontal surfaces of the larger disks where the liquid is immobilized. The whole is held in central position by two large circular plates in the edges of which it is convenient to have cut a couple of notches through which samples of liquid may be withdrawn, with a fine pipet or hypodermic syringe, for analysis. The disks must be made of material indifferent to the solution studied and, to avoid electrical couples, should be made of the same metals throughout if salt is present. The interior of the rotor is best coated with several appli-

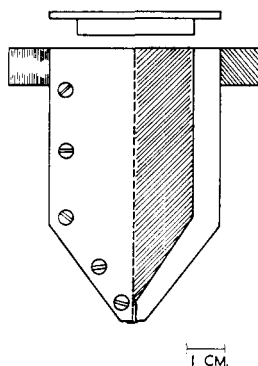

FIG. 8. Metal cuvette for filling and emptying inserts in ordinary centrifuge

cations of Bakelite lacquer, each baked on for 30 min. at 150°C. The disks may be of metal or plastic material, but must withstand the centrifugal force.

Inserts fill spontaneously with liquids of low surface tension, but it may be advisable to place them in a suitable cuvette (figure 8) filled with liquid, for a few moments in an ordinary centrifuge. If the bottom of the cuvette has a slight depression it may also be used for emptying them and collecting the previously immobilized liquid for analysis.

METHOD OF CALCULATION

For sedimentation equilibrium McBain and Tostado (20) have developed a formula suitable for the insert they employed in measuring sucrose (molecular weight: found, 341; theoretical, 342). A corresponding formula has been developed by Leyda for the insert of figures 3 and 4.

For sedimentation velocity by the analytical method, Tiselius, Pedersen, and Svedberg (36) give the formula

$$s_{(\text{observed})} = \frac{1}{2\omega^2 t} \ln \left(1 - \frac{2\Delta}{qxc_0} \right)$$

where ω = angular velocity = 2π (R.P.S.), t is the time in seconds, Δ is the change in amount of substance above or below the level at which the separation is made, x is the distance in centimeters of this level from the center of rotation (radius of larger disks of the McBain and Leyda rotor), q is the cross-sectional area of the cell at this level, and c_0 is the original concentration within the cell. ω , t , x , and q are obtained readily from the dimensions of the insert and observations during the run. In order to apply the analytical method, Tiselius, Pedersen, and Svedberg (36) place a porous partition in the middle of their transparent cell.

McBain and Leyda deduce the formula

$$s_{(\text{observed})} = \frac{2.303(\log x_2 - \log a)}{39.48(\text{R.P.S.})^2 t}$$

where x_2 is the position which the boundary would occupy if no diffusion occurred. This is readily calculated from the dimensions of the insert and from the analysis of the original and final concentrations of the liquid. This possesses for many cases the very great advantage that the absolute concentration need not be known, but only the relative concentrations on any convenient scale.

SEMI-CONVECTIVE METHODS

Elford (6, 8, 9, 35) has used inverted glass, silica, or metal tubes, of 1 to 3 mm. internal diameter, immersed in a commercial or in a Henriot and Huguenard air-driven centrifuge. Such a design is illustrated in figures 9 and 10, where many parallel holes in one block may be used to give larger volumes. Alternatively we have used with success in this same rotor a capillary tube closed at one end and held in position with a cork, obtaining a boundary with the 70-mm. rotor, where with the same tube inserted in a 37-mm. rotor (figures 3 and 4) a boundary was not formed.

When the tubes are sufficiently narrow and the centrifuge sufficiently free from vibration and thermal gradients, Elford found that his tubes resembled an ultracentrifuge, in that a definite boundary appeared, which could be seen with the naked eye by scattered or fluorescent light and the position of which could be measured after stopping the centrifuge. Fur-

thermore, the boundary moved within the experimental error with the same velocity as that observed in the Svedberg ultracentrifuge.

This is at first surprising, for the cell is cylindrical, not radial, and some of the sedimentation must be directed obliquely against the walls of the

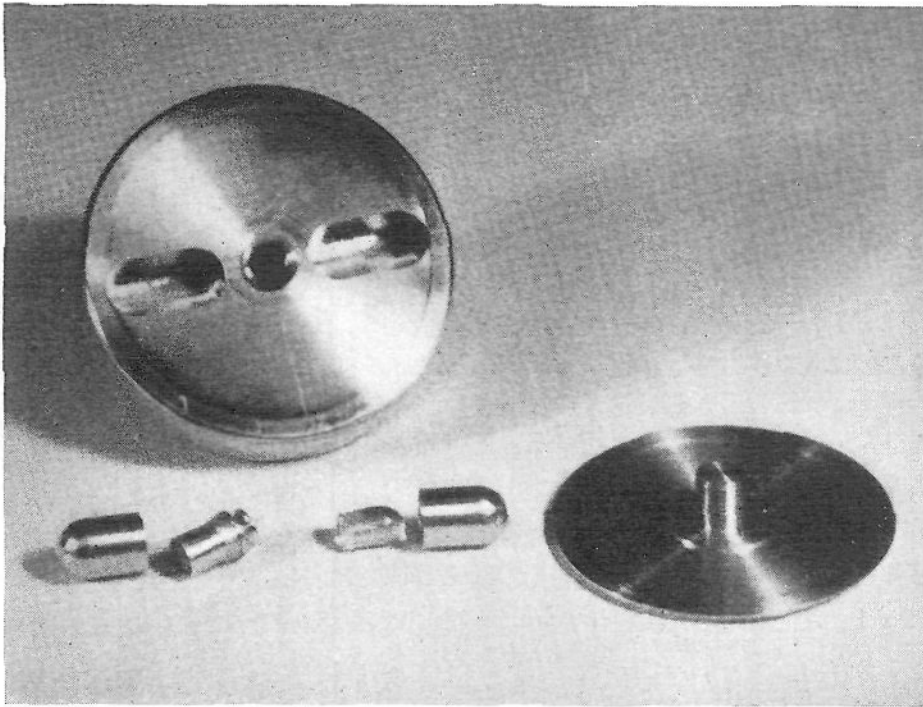

FIG. 9. Seven-centimeter air-driven rotor, showing recesses for either immersed multiple holes, or simple thick capillary tube closed at one end, with large cover for streamlining.

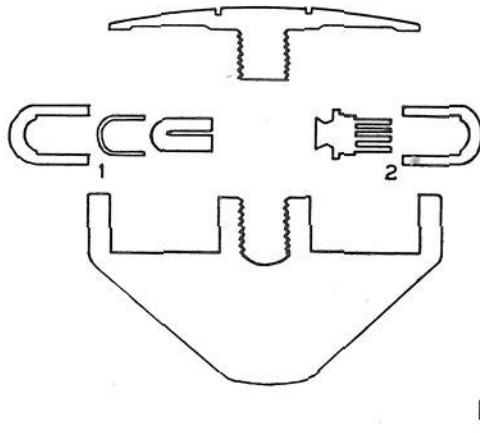

FIG. 10. Cross section of 7-cm. air-driven rotor, showing recesses for (1) simple thick capillary tube closed at one end or (2) immersed multiple holes.

tube. Thus a sheath of liquid in contact with the walls of the tube must move steadily downwards and correspondingly elevate the central contents, including the boundary. Our explanation of the fact that correct

results are obtained is that the movement is slow and controlled and confined to a layer next to the walls, which is only a few molecules or particles thick and is therefore of a volume negligible in comparison with the contents of the tube.

McBain (18) pointed out that, since the sedimentation velocity depends upon the actual specific volume of the particle as well as the density of the solution, the actual density of the particle may be determined by suitable additions to change the density of the solution. Giving a formula confirmed by Kraemer and Lansing (15), he showed that sedimentation velocity is as little affected by hydration in a binary system, consisting of solvent and only one solute, as is any osmotic property such as the lowering of the freezing point. It is far different when further additions, such as buffers, are present, for the particle may be made to sediment either upwards or downwards, and thus its actual density is determined. From the actual, as compared with the partial, specific volume of the anhydrous material the actual hydration or solvation may be found. Using this principle Elford (7) has found the density of vaccinia virus to be 1.17 ± 0.02 and that of two of the largest bacteriophages—*Staphylococcus* "K" and *Coli* "WLL"—to be 1.22 ± 0.02 . Many other similar determinations of density have now been made, such as those made by McIntosh and Selbie (24, 25).

Schlesinger (30, 31) has used a successful device for converting a Sharples supercentrifuge into a semi-convectionless ultracentrifuge. Five cubic centimeters of virus solution gelatinized with dilute agar lines the closed bowl to a depth of 0.18 mm. Another 5 cc. is then added. The film is so thin that convection does not occur, thus allowing both rate and equilibrium to be measured. Virus of foot-and-mouth disease is measured after 3 min. An antibody required only 30 min. for sedimentation equilibrium. It is necessarily assumed that the agar jelly is of such concentration that it neither swells nor sediments. This, however, can be verified by direct experiment and by adjusting the concentration of agar to the requisite value. Any influence of the agar on the absolute rate has to be tested by comparison in some other ultracentrifuge. Sedimentation equilibrium is of course unaffected.

THE CONVECTIVE PROCEDURE

The Bechhold-Schlesinger convective procedure (2, 29) was originated in 1931, and during the last eight years (5, 8, 9, 11, 12, 13, 24, 25, 27, 28, 35, 37) various qualitative and semi-quantitative observations of its occurrence have been made in the author's laboratory at Stanford (as, for example, with methylene blue, etc.), in that of Beams at Virginia, and also by Gratia in Belgium, using the simplest form of the one-piece hollow rotor of Henriot and

Huguenard (14). If the outer periphery of a centrifuge is of such a nature that through porosity, adhesion, or coagulation every particle sedimented against that periphery remains therein, the liquid remains of uniform composition which, however, decreases asymptotically with time in accordance with a formula of Bechhold and Schlesinger. From this one may calculate sedimentation velocity. It has not been sufficiently emphasized in recent years that, when the centrifugation is carried to near exhaustion of the solution, the final concentration becomes extraordinarily sensitive to particle size. This may sometimes be by far the most accurate method of examination.

It is interesting that if the rotor is filled with liquid to the center and the outer periphery has the property of holding all sedimented particles, there is no difference between a convectionless ultracentrifuge and a thoroughly stirred centrifuge.

The convective method has been used by McIntosh and Selbie (24, 25) for quantitatively determining the sedimentation velocity and actual densities of bacteria, viruses, bacteriophages, and oxyhemoglobin. For example, they obtained a diameter of 56 Å. for oxyhemoglobin, identical with that quoted from Svedberg. Their equipment was very similar to that in figures 9 and 10. The density of spores of *B. subtilis* was found to be 1.46, and that of phages and *Staphylococcus aureus* 1.25. In solutions of higher density they sedimented upwards.

Païc (28, 5, 27, 37) has suggested the standardization of the sedimentation velocity constant of an unknown by comparison with that of a known in the same centrifuge, and has deduced the theoretical ratios with and without convection, respectively. However, he found the relation

$$s/s' = \varphi \cdot t'/t$$

where t and t' are the respective times required to reduce the concentration of the known and the unknown by the same fraction in the same centrifugal field, and φ is a simple allowance for the respective partial specific volumes.

Gratia (11, 12, 13) and Païc (28, 5, 27, 37) and their respective collaborators have studied serums, venoms, antibodies, antitoxins, antigens, lysins, and syphilitic reagents.

REFERENCES

- (1) ARCHIBALD: Phys. Rev. **53**, 746 (1938); **54**, 371 (1938).
- (2) BECHHOLD, H., AND SCHLESINGER, M.: Biochem. Z. **236**, 392 (1931); Z. Hyg. Infektionskrankh. **112**, 668 (1931); **115**, 342, 354 (1933); Phytopath. Z. **6**, 627 (1933).
- (3) BURK, N. F.: J. Biol. Chem. **121**, 373 (1937); **120**, 63 (1937).
- (4) BURK, N. F., AND GREENBURG, D. M.: J. Biol. Chem. **87**, 197 (1930).

- (5) DEUTSCH, V., AND LOMINSKI, I.: Bull. acad. méd. **118**, 220 (1937).
- (6) ELFORD, W. J.: Brit. J. Exptl. Path. **17**, 399 (1936).
- (7) ELFORD, W. J.: Proc. Roy. Soc. (London) **B125**, 309-10 (1938).
- (8) ELFORD, W. J., AND ANDREWES, C. H.: Brit. J. Exptl. Path. **17**, 422 (1936).
- (9) ELFORD, W. J., AND GALLOWAY, I. A.: Brit. J. Exptl. Path. **18**, 155 (1937).
- (10) FAXEN, H.: Ann. Physik [4] **68**, 89 (1922).
- (11) GRATIA, A.: Bull. soc. chim. biol. V^e congrès **18**, 208 (1936); Compt. rend. soc. biol. **117**, 1228 (1934).
- (12) GRATIA, A., AND GORECKI: Compt. rend. soc. biol. **126**, 900, 1252 (1937).
- (13) GRATIA, A., AND NELIS, P.: Compt. rend. soc. biol. **127**, 840 (1938).
- (14) HENRIOT AND HUGUENARD: Compt. rend. **180**, 1389 (1925); J. phys. radium **8**, 433 (1927).
- (15) KRAEMER, E. O., AND LANSING, W. D.: J. Am. Chem. Soc. **55**, 4319 (1933); J. Phys. Chem. **39**, 165 (1935).
- (16) LORENZ, H. A.: Abhandl. theor. Physik **1**, 23 (1906).
- (17) MASON, M., AND WEAVER, W.: Phys. Rev. **23**, 412 (1924).
- (18) MCBAIN, J. W.: J. Am. Chem. Soc. **55**, 4319 (1933).
- (19) MCBAIN, J. W.: J. Phys. Chem. **42**, 1063 (1938), figure 3.
- (20) MCBAIN, J. W., AND ALVAREZ-TOSTADO, C.: Nature **139**, 1066 (1937); J. Am. Chem. Soc. **59**, 2489 (1937).
- (21) MCBAIN, J. W., AND LEYDA, F. A.: J. Am. Chem. Soc. **60**, 2998 (1938); Nature **141**, 913 (1938).
- (22) MCBAIN, J. W., AND O'SULLIVAN, C.: J. Am. Chem. Soc. **57**, 780, 2631 (1935).
- (23) MCBAIN, J. W., AND STUEWER, R. F.: Kolloid-Z. **74**, 10 (1936).
- (24) MCINTOSH: J. Path. Bact. **41**, 215 (1935).
- (25) MCINTOSH AND SELBIE, F. R.: Brit. J. Exptl. Path. **18**, 162 (1937).
- (26) MEYER, K. H., AND LUDHEMANN, R.: Helv. Chim. Acta **18**, 307 (1935).
- (27) PAIĆ, M.: Compt. rend. **207**, 629, 1074 (1938).
- (28) PAIĆ, M., AND CHOROKHOFF, M.: Compt. rend. soc. biol. **126**, 877 (1937).
- (29) SCHLESINGER, M.: Z. Hyg. Infektionskrankh. **114**, 161 (1932); Biochem. Z. **264**, 6 (1933); Kolloid-Z. **67**, 135 (1934); Biodynamica **1935**, 1.
- (30) SCHLESINGER, M.: Nature **138**, 549 (1936).
- (31) SCHLESINGER, M., AND GALLOWAY, I. A.: J. Hyg. **37**, 445, 463 (1937).
- (32) STEINHARDT, J.: J. Biol. Chem. **123**, 543 (1938).
- (33) SVEDBERG, T.: Ind. Eng. Chem., Anal. Ed. **10**, 116 (1938).
- (34) SVEDBERG, T.: Ind. Eng. Chem., Anal. Ed. **10**, 118 (1938).
- (35) TANG, F. F., ELFORD, W. J., AND GALLOWAY, I. A.: Brit. J. Exptl. Path. **18**, 269 (1937).
- (36) TISELIUS, A., PEDERSEN, K. O., AND SVEDBERG, T.: Nature **140**, 848 (1937).
- (37) VIEUCHANGE, J., AND PAIĆ, M.: Compt. rend. **206**, 1318 (1938).
- (38) WEAVER, W.: Phys. Rev. **27**, 499 (1926); Z. physik **43**, 296 (1927); **49**, 311 (1928).
- (39) WEBER, H. H., AND STÖVER, R.: Biochem. Z. **259**, 269 (1933).
- (40) WILLIAMS, J. W., AND WATSON, C. C.: Nature **139**, 506 (1937).